



**ISD9160 Demo Board  
Rev D User's Manual**

The information described in this document is the exclusive intellectual property of Nuvoton Technology Corporation and shall not be reproduced without permission from Nuvoton.

Nuvoton is providing this document only for reference purposes of ISD ChipCorder microcontroller based system design. Nuvoton assumes no responsibility for errors or omissions.

All data and specifications are subject to change without notice.

For additional information or questions, please contact: Nuvoton Technology Corporation.

***Table of Contents***

1	INTRODUCTION.....	4
2	JUMPER AND BUTTONS.....	5
3	DEMO CODE .....	6
	3.1 Operation .....	6
	3.2 More functions .....	6
4	BOARD SCHEMATIC .....	8
5	REVISION HISTORY .....	9

***Table of Figures***

Figure 1: Demo board top side.....	4
Figure 2: Demo board and ISD-9160_Touch.....	7

# 1 Introduction

The ISD9160 demo board is a small board, its dimension is around 42mm by 67mm. All function pins are layout to the connectors for easy expansion. It is convenient for demo use, and also could be used for development with ISD-Nu-Link-dongle.

This document only describes demo code, demo board hardware, jumper function and schematic. User can refer to the "Introduction to ISD9160 Development Environment" for the project development & tools function to get the overall development concept.

Below is the picture of ISD9160 demo board, all components are on the top side except the SPI-flash related which are on the back.

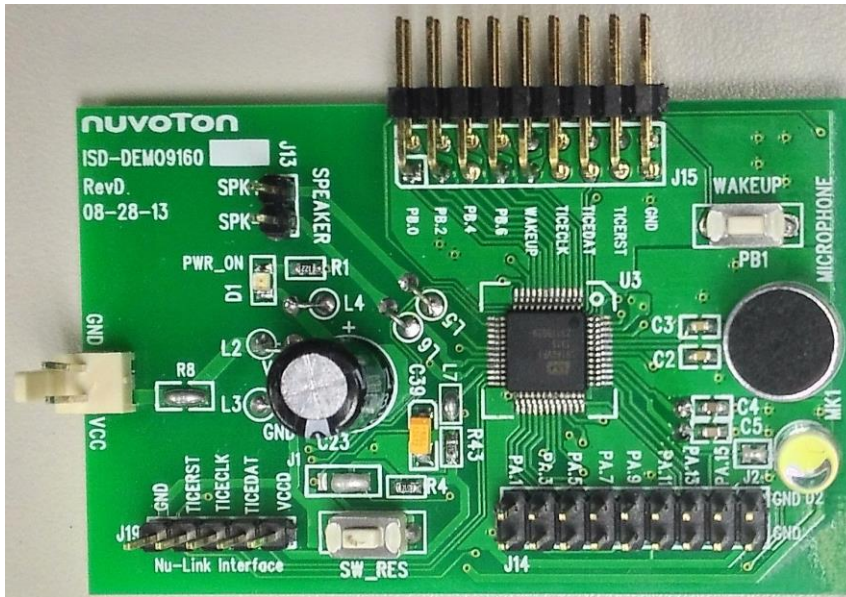

Figure 1: Demo board top side

## 2 Jumper and buttons

Component Name	Description	Default
J1	SW_RES button selection for RESETN or GPA6	Pin 1, 2 & 3 short for GPA6 scanning. <b>No reset key.</b>
J2	Option for D2 LED driving by GPA12	Short for LED driving by GPA12
J12	Power input	
J13	Speaker signal output.	
J14	GPIOA port connector	
J15	GPIOB port connector. Also can connect with ISD-9160_Touch for touch sensing function.	
J19	ISD dongle interface for programming or debugging	
WAKEUP (PB1)	Wakeup key for wakeup from deep power down	Open and pull-high
SW_RES	Reset key or GPA6 key, based on J1 setting	GPA6 key

### 3 Demo code

Normally a VR light control demo code was programmed before shipping. User can try the demo code function with default jumper setting.

#### 3.1 Operation

- SPI-flash Record/Play (Siren7, 16Kbps, 16K sampling rate)

SW\_RES button is default set to GPA6 connection (no reset function). This key supports multi functions Record/Play/Stop. Pressing this button can play the recorded sound or stop the playing/recording. Pressing over 2 second will have a prompt sound, and will start recording sound into SPI-flash once button released. Only one recorded sound is allowed in this code, record again will overwrite the previous recorded sound.

- Voice Recognition:

VR function is always on except Record or Play function is processing. The below table is the command and description.

**Environment:** Office environment, no loud background sound. (The speaking should be 20dB louder than environment sound.)

**Best Distance:** within 30 cm (from MIC).

Note: Need to adjust the program and trade off the distance under noisy environment.

Voice Command	Description
Sandy	An ID command to enable the following four action commands, a prompt sound will be played once ID command recognized. User can speak the action command within 2 seconds after the prompt sound.
Lights Off	The D2 LED will be off
Turn Lights On	The D2 LED will be on with full brightness.
Dimmer	Decrease the brightness with prompt sound, 3 stages including full brightness. Only works when lights on
Brighter	Increase the brightness with prompt sound, 3 stages including full brightness. Only works when lights on.

#### 3.2 More functions

Default jumper setting only supports VR function & SPI-flash record/play. The below settings support more functions.

- Play preprogrammed sound (Siren7, 16Kbps, 16K sampling rate)

Additional jumper could be put to connect the GPB6 & WAKEUP pins of J15. This is to support the preprogrammed sound playing with WAKEUP (PB1) button. There are two pre-programmed sounds in ISD9160 flash and one sound in SPI-flash. PB1 is Play/Stop key. Pressing PB1 will cyclically play these sounds. Pressing PB1 can stop playing if sound is being played.

- Remove the GPB6-WAKEUP jumper. User can connect the touch pad (ISD-9160\_Touch) on J15, please refer to the below figure. CS4 of touch pad supports the D2 light on/off control.

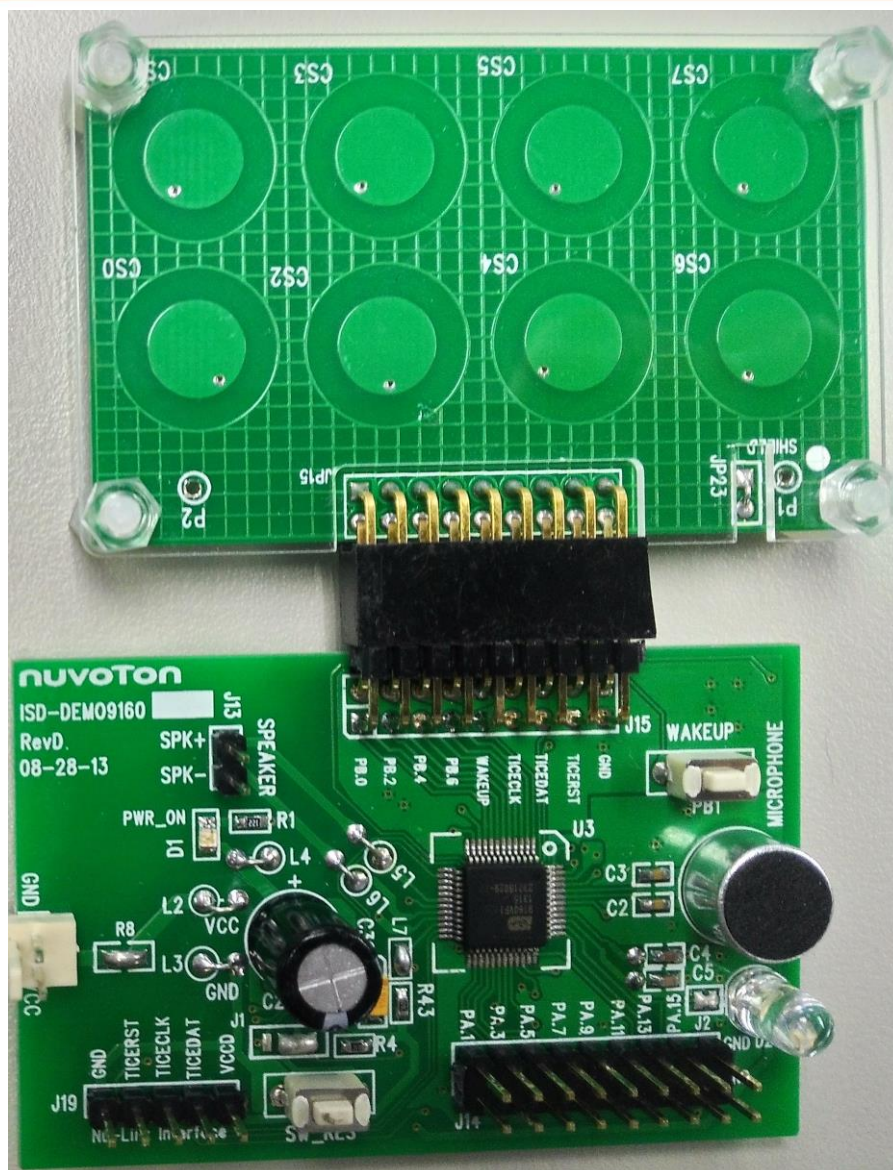
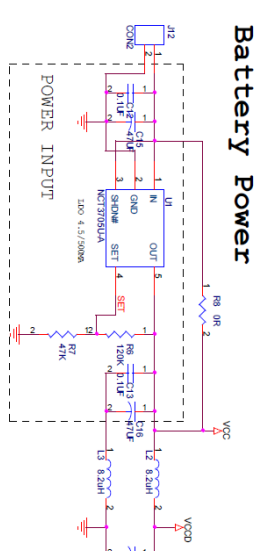
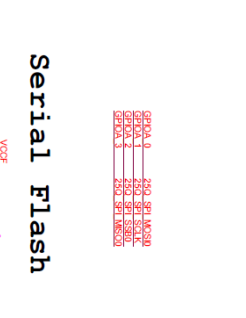
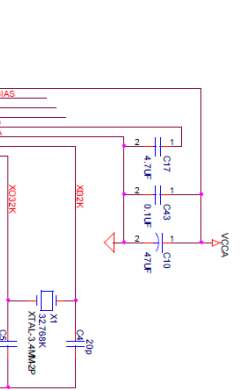
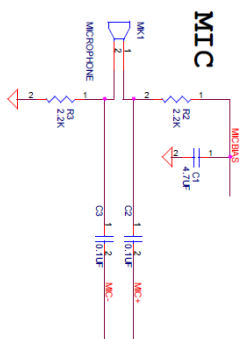
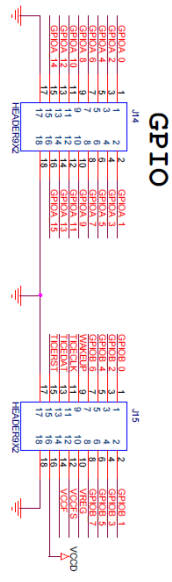

Figure 2: Demo board and ISD-9160\_Touch



# 4 Board Schematic



NOTE: 1. For BFT testing, you maybe need to add some protect circuit. For example, you could use LDO circuit.

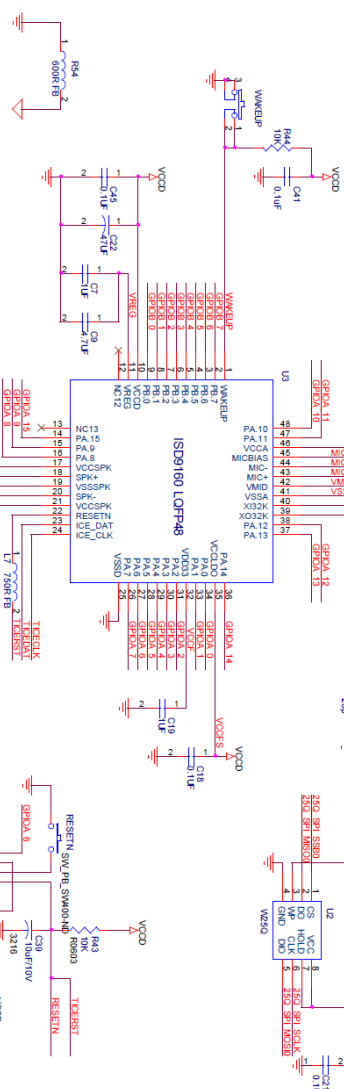
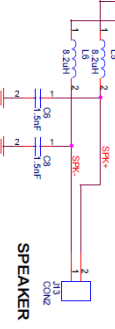
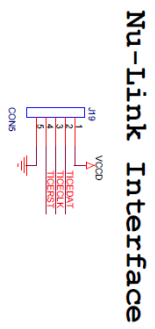
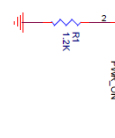



## 5 Revision History

VERSION	DATE	PAGE/ CHAP.	DESCRIPTION
V1.0	Oct. 8, 2013	-	First Release.
V1.1	Apr. 8, 2016	-	Description update.

### Important Notice

Nuvoton products are not designed, intended, authorized or warranted for use as components in systems or equipment intended for surgical implantation, atomic energy control instruments, airplane or spaceship instruments, transportation instruments, traffic signal instruments, combustion control instruments, or for other applications intended to support or sustain life. Furthermore, Nuvoton products are not intended for applications wherein failure of Nuvoton products could result or lead to a situation where personal injury, death or severe property or environmental damage could occur.

Nuvoton customers using or selling these products for use in such applications do so at their own risk and agree to fully indemnify Nuvoton for any damages resulting from such improper use or sales.

---

Please note that all data and specifications are subject to change without notice. All the trademarks of products and companies mentioned in this datasheet belong to their respective owners.